

KS-508-3W/9W



Feature:

1. LED Spot Light
2. LED Color : Cool White, Warm White
3. Energy-saving and environment-friendly
4. Low power consumption
5. Great heat dissipation
6. Low malfunction rate
7. Easy repair
8. Low heat emission rate and low disposal rate
9. No UV or IR radiation
10. Long Lifespan: 50,000 hours
11. Working Temperature: -40~50 degrees celsius
12. Brightness Degradation: 3%~5% /1kh

Application:

LED spotlight can be applied to hotels, malls, shop windows, cafés, bars, etc. as decorative lighting for various commercial places. They also can be applied to offices, meeting rooms, exhibition halls, etc. as interior lighting.

Basic Specification:

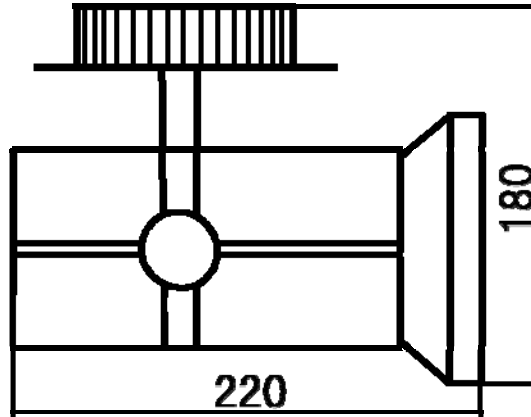

Item No.	LED Power	LED QTY	LED Type	Luminous Flux	Weight / PC	Color Temperature
KS-508-3W	3W	3*1W	Edison	cool white : 270 LM	N.W.: 1400g	(CW) 5500-6500K (WW) 2700-3500K
				warm white : 180 LM		
KS-508-9W	9W	3*3W	Cree	cool white : 510 LM	G.W.: 1550g	
				warm white : 420 LM		

Input Voltage : 100 - 240V AC 50Hz -60Hz

Output Current : 350±5% -700±5% mA

LED Color : Cool White ; Warm White

Dimension : 180mm×220mm

Beam Angle : 15°/25°/45°/60°

Material : Aluminum, PMMA, Alloy

Lifespan : 50,000 hours



2 years
Warranty

Installation Instruction:

- 1.AC 100-240V Working directly
- 2.Working Temperature: -40~50 degrees celsius

Packing

3*1W

1pc/white box, 9pcs/carton
Carton Size: 325*585*500mm
N.W.: 14.3KG
G.W.: 15.5KG

3*3W

1pc/white box, 9pcs/carton
Carton Size: 325*585*500mm
N.W.: 14.3KG
G.W.: 15.5KG

Product Warranty :

Kam's LED Light has 2-year warranty from the date of shipment from our factory. Within this period product failures which are related to defective material or workmanship will be repaired or completely replaced free of charge to customers.

Warranty claims for normal degradation of LED Light output over time is excluded. Product damages caused by inappropriate or negligent handling can not be claimed under warranty conditons. We will pay for the freight, handling & insurance charges of both sending back defective products in accordance with our warranty clause to us and the sending the repaired / replaced product to customer.

Notice:

- 1.No pressing or striking
- 2.Transport and handle carefully
- 3.Pay attention to the voltage before using
- 4.Indoor use only
- 5.No twisting when power is on